



2021 CORVETTE Z51 TRACK PREPARATION



Corvette Stingray with the Z51 Performance Package has been designed and engineered to be a world-class sports car for the track. But before unleashing its acceleration, cornering and braking capability, there are several key procedures and steps that must be taken. This guide includes an overview of requirements and recommendations. These are general guidelines and are not all-encompassing. Use good judgment at all times to determine the appropriate adjustments and speeds for the track configuration and environmental conditions.

The Owner's Manual contains important restrictions, precautions and safety procedures. Always read and follow all of the instructions in the vehicle Owner's Manual.

DANGER: High-performance features are intended for use only on closed tracks by experienced and qualified drivers and should not be used on public roads. High-speed driving, aggressive cornering, hard braking, and other high-performance driving can be dangerous. Improper driver inputs for the conditions may result in loss of control of the vehicle, which could injure or kill you or others. Always drive safely.

Note: This supplement is for Corvette Stingray with Z51 Performance Package. Vehicles without the Z51 package should not be used for track events and competitive driving. Track events or competitive driving may affect the vehicle warranty. See the warranty manual before using the vehicle for track events or other competitive driving.

1. ATTAIN THE RIGHT MILEAGE

NEW VEHICLE BREAK-IN

All Corvette models have a recommended break-in period during the first 1,500 miles (2414 km).

PART/DRIVING BEHAVIOR	TIME PERIOD	RECOMMENDED ACTION
Tires	First 200 miles (322 km)	Drive at moderate speeds and avoid hard cornering
Brake linings	First 200 miles (322 km)	Avoid making hard stops (recommended every time brake linings are replaced)
Full-throttle starts and abrupt stops	First 500 miles (800 km)	Avoid full-throttle starts and abrupt stops
Exceeding 4000 rpm	First 500 miles (800 km)	Avoid exceeding 4000 rpm
Cruise control or driving at one constant speed	First 500 miles (800 km)	Avoid cruise control or driving at one constant speed
Track or competitive driving	First 1,500 miles (2414 km)	Do not participate in track events, sport driving schools or similar activities
Engine oil maintenance	First 1,500 miles (2414 km)	Check engine oil with every refueling and add if necessary (oil and fuel consumption may be higher than normal during the first 1,500 miles)



2021 CORVETTE Z51 TRACK PREPARATION

2. PREPARE THE BRAKES

WARNING: Some of the adjustments and procedures specified in this section may require specialized skill, training and equipment. Failure to perform these procedures properly could cause malfunction, potentially resulting in death, personal injury or damage to the vehicle or property. Do not attempt to perform these adjustments or procedures unless properly qualified.

SERVICE NOTE: DISCONNECT THE BATTERY BEFORE SERVICING THE HYDRAULIC BRAKE SYSTEM.

Due to the new electro-hydraulic brake apply system, it is critical to disconnect the battery before servicing the brake system, including before bleeding the system, replacing the pads, or any other work on the hydraulic braking system. The battery must be disconnected to prevent the brake master cylinder from pressurizing the hydraulic system during its automated self diagnostic tests that can possibly occur when a door is opened or the key transmitter is activated.

Bleeding the brake system with the battery connected can also lead to the system diagnosing a leak or air in the braking system, potentially resulting in a fault and vehicle speed limitation.

BRAKE FLUID

Replace existing brake fluid with a qualified DOT4 high performance brake fluid from a sealed container. Brake fluid with a dry boiling point $>310\text{ }^{\circ}\text{C}$ ($590\text{ }^{\circ}\text{F}$) is qualified. If high performance brake fluid is used, replace it with GM approved brake fluid before driving on public roads. If high performance brake fluid is in the vehicle and the age of the brake fluid is over a month old or unknown, replace the brake fluid before track events and competitive driving. Do not use silicone or DOT-5 brake fluids.

Note: It is critical to disconnect the negative battery cable when any brake fluid flush procedures are performed. Flush the brake system, either manually bleeding or pressure bleeding is required. Vacuum bleeding is not recommended.

Check the fluid level before each driving event

BRAKE SYSTEM FLUSHING & BLEEDING

The J55 Brake system requires specific processes for bleeding and fluid flushing. These can be found in the service manual (information provided in the owner's manual).

Properly bleeding the brake system is required for proper operation of the electro-hydraulic brake system diagnostic procedures.

BRAKE LEAK DETECTION

The electro-hydraulic braking system has advanced diagnostic capability to help detect hydraulic leaks, trapped air, and other performance issues. These diagnostics are active when the electro-hydraulic system is powered. In order to avoid inadvertently setting a leak fault, disconnect the battery before servicing the brake system.



2021 CORVETTE Z51 TRACK PREPARATION

If the vehicle sets a fault related to a brake system leak, it will set a Service Brake System indicator light and potentially limit vehicle speed to 100KPH/62MPH. Anytime a leak fault is set, the vehicle should be inspected carefully for evidence of a leak and any leak should be repaired immediately.

Once the leak has been repaired, or the system has been properly bled, the following procedure will confirm proper operation of the system, with no leaks or trapped air. This procedure will clear the fault if the vehicle is operating correctly.

BRAKE LEAK DETECTION FAULT C2A20

This fault indicates trapped air or a leak in the brake hydraulic circuit, and the DIC displays “Brake System Failure – Speed Limit 100KPH/62MPH”. If this fault is set during a brake bleed or other brake service procedure, the following process will confirm that the circuit is good once the brake system is properly bled. If this code persists in being set, there is a leak present that has not been properly diagnosed and must be repaired.

Ignition/Vehicle » Off – For greater than 10 min

Ignition » On (green light) / Engine » Off – For greater than 15 s – Brake Pedal Not Applied

Apply and hold the brake pedal. – For less than 120 s & full effort brake pedal apply

If the leak has been repaired, the Brake warning indicator malfunction will turn off

If the leak persists, the lamp will remain on and the vehicle needs to be serviced

BRAKE FADE WARNING ASSIST

The Brake Fade Warning Assist system monitors the performance of the brake system. If the system detects brake fade, or if the brake fluid is near the boiling point, the driver will be alerted. The Brake Fade Warning Assist system is designed for use with the factory-installed brake pads or GM-approved replacement pads. If the brake pads on the vehicle need to be replaced, use GM-approved brake pads. If this is not done, the brake fade warning system may not function properly.

STAGE 1

The Driver Information Center (DIC) displays a “Reduce Braking to Avoid Overheating” message, a chime sounds and brake pedal effort and travel is increased. When the message displays, the driver should back up braking points and reduce brake usage in order to reduce brake temperature. This will allow for continued lapping with no speed limitations.

STAGE 2

The Driver Information Center (DIC) displays a “Brakes Overheated Service Now” message, a chime sounds, and brake pedal effort and travel is further increased. This code indicates that the brake fluid temperature is excessive and is about to boil. The system limits vehicle speed to 100KPH/62MPH. The driver should immediately start a cool down lap if on the track. If this message displays, the vehicle needs to be serviced. The brake system needs to cool down, and the brake fluid must be immediately flushed with DOT4 for street use, or to a qualified DOT4 race fluid for track use. Boiled brake fluid is compromised and must be replaced.

To restore normal operation, if no GM service tool is available, the following should be completed:

Cool brakes

Inspect system for leaks (a boil can behave similarly to a leak), repair as necessary

Flush brake fluid that has experienced boil (follow proper bleeding procedures with battery disconnected)

Car must be parked for at least 10 minutes, key off

Perform at least three easy to moderate brake applies while driving

Brake System will measure itself during brake application, DIC message and brake warning indicators will extinguish when normal operation is restored.



2021 CORVETTE Z51 TRACK PREPARATION

BRAKE BURNISHING

New brake pads must be burnished before racing or other competitive driving.

BRAKE BURNISHING PROCEDURE

STEP 1	STEP 2	STEP 3	STEP 4
Apply the brakes 25 times, starting at 60 mph (100 km/h) to 30 mph (50 km/h), while decelerating at 0.4 g. This is a medium brake application. Drive for at least 0.6 mi (1 km) between applying the brakes. This first step may be skipped if there are more than 200 mi (320 km) on the brake pads.	Apply the brakes 25 times, starting at 60 mph (100 km/h) to 15 mph (25 km/h), while decelerating at 0.8 g. This is a hard brake application without activating the antilock brake system (ABS). Drive for at least 0.6 mi (1 km) between applications. Depending on conditions, some increase in brake pedal travel and brake pedal force may be experienced.	Cooldown: Drive at 60 mph (100 km/h) for approximately 10 mi (15 km) without using the brakes.	Apply the brakes 25 times, starting at 60 mph (100 km/h) to 30 mph (50 km/h), while decelerating at 0.4 g. This is a medium brake application. Drive for at least 0.6 mi (1 km) between applications.

ALTERNATIVE CLOSED COURSE BRAKE BURNISHING PROCEDURE

This brake burnish procedure should only be run on vehicles with the J55 Z51 factory equipped brake system. This procedure should only be run on a track and only on dry pavement. Brake pedal fade will occur during this track burnish procedure and can cause brake pedal travel and force to increase. This could extend stopping distance until the brakes are fully burnished.

STEP 1	STEP 2	STEP 3
Start track lapping at lower speeds and lower braking efforts for 3 minutes of driving. Allow for increased braking distances due to reduced brake output.	After Step 1, increase speed and braking effort for the next 6 minutes of lapping, gradually ending up at 90% effort. Continue to allow for increased braking distance due to reduced brake output.	Cool the brakes by lapping with minimal light braking for 6 minutes.

BRAKE COOLING KIT

The brake cooling ducts should be visually inspected prior to any track event, high speed braking, or competitive driving. Part 4 below (Rear lower control arm cooling duct) is not dealer installed for highway use but must be installed prior to track use. Part 4 should be removed after track use to prevent debris from being channeled into the rear brakes during normal street use.

Ensure all brake cooling parts are correctly and securely installed.

Inspect for blockage in the front and rear brake cooling ducts prior to every event.

1. Front Brake Cooling Duct
2. Front Lower Control Arm Deflector
3. Rear Knuckle Mounted Cooling Duct
4. Rear Lower Control Arm Cooling Duct

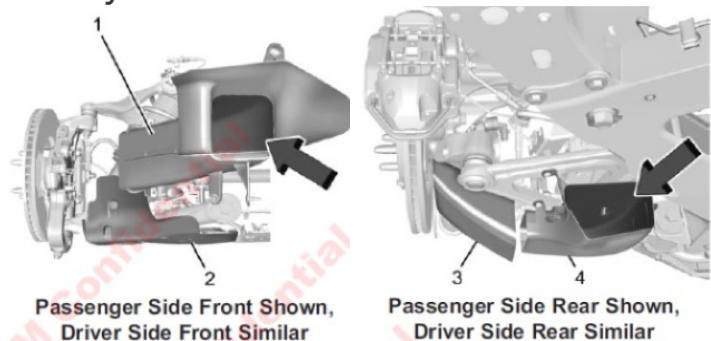



2021 CORVETTE Z51 TRACK PREPARATION

3. ADJUST FOUR CORNERS AND ALIGNMENT

WARNING: Some of the adjustments and procedures specified in this section may require specialized skill, training and equipment. Failure to perform these procedures properly could cause malfunction, potentially resulting in death, personal injury or damage to the vehicle or property. Do not attempt to perform these adjustments or procedures unless properly qualified.

SHOCK SPRING SEAT ADJUSTMENT, TIRE PRESSURES AND ALIGNMENT

The front shocks, on vehicles without hydraulic front lift and rear shocks, have threaded spring seats that allow adjustment of the vehicle ride height. The vehicle corner weights can be adjusted for track use. If the vehicle ride height is modified, it should be returned to normal ride height before street use.

The spring seat can be adjusted approximately 0.8 in (20 mm) up or down from the nominal position. Each complete turn of the spring seat will change the vehicle height approximately 0.06 in (1.5 mm). When adjusting the seat to the upper limit, lift the dust boot and ensure the seat does not thread off the center support tube. Stop adjustment when threads are no longer visible. When adjusting the seat to the lower limit, leave approximately 0.4 in (10 mm) of thread visible for the lower lock nut to have full thread engagement.

To adjust the lower spring seat:

STEP 1	STEP 2	STEP 3	STEP 4	STEP 5
Raise the vehicle so the tires are completely off the ground.	Loosen the lower spring seat lock nut.	Thread the lower spring seat lock nut downward off of the threads to its resting location on the shoulder of the center support tube.	While holding the center support tube holes, turn the spring seat upward to raise the vehicle height, or downward to lower the vehicle height	Thread the lower lock nut back on to the center support tube and torque it against the spring seat to 18.4 lb.-ft. (25 nm).

LOAD LIMIT

Limit vehicle load to the driver only, with no other cargo.

TIRE PRESSURES

Inflate the front tires to 159 kPa (23 psi) and the rear tires to 165 kPa (24 psi). Road Course target hot pressures of 220–240 kPa (32–35 psi). Value will vary based on driving style, track, temperature, and weather.

WARNING: Tracks/courses put high loads on tires operating at high speed, which can lead to tire failure if not inflated properly. Improper tire inflation pressure can put additional strain on the tires and can cause a sudden failure. Make sure the tires are in excellent condition and use the correct cold tire inflation pressure for the vehicle load and track/course.



2021 CORVETTE Z51 TRACK PREPARATION

WARNING: Track/course loads wear tires both on the tread and internal to the tire. When driven in track/course conditions, even if tread is not worn down to the treadwear indicator, tires must be replaced after the equivalent of two tanks of fuel or approximately 160 km (100 mi).

WHEEL ALIGNMENT

Caution: Do not use power tools when removing or installing the fasteners. Damage to the threads may occur. Use hand tools only, and do not overtighten. Hand start the fasteners to ensure that the threads do not bind or cross thread.

The racing and competitive driving wheel alignment settings should be set as described here. To achieve the track alignment specified settings:

1. The upper control arm to body washers on all four corners will need to be relocated from between the body and the control arm to between the head of the bolt and the control arm.
2. Adjust the lower control arm cam bolt position to achieve the following specifications.

FRONT (PER CORNER)	REAR (PER CORNER)
<ul style="list-style-type: none">/ Caster: +8.0 degrees/ Camber: -3.0 degrees/ Toe (total): 0.1 degrees toe in	<ul style="list-style-type: none">/ Caster: 0 degrees/ Camber: -2.5 degrees/ Toe (total): 0.1 degrees toe in/ Thrust Angle: 0 degrees

Note: After track use, reinstall washers between the body and the control arms. Reset to factory alignment.

4. FLUID LEVELS

CHECK ENGINE OIL LEVEL

If the vehicle is used for track events and competitive driving, the engine may use more oil than it would with normal use. Low oil levels can damage the engine. Check the oil level often and maintain the proper level.

0W-40 dexos2™ engine oil is approved for both track and street use. 15W-50 full synthetic engine oil may also be used for track use, but after track use must be changed back to 0W-40 dexos2 for street use.



2021 CORVETTE Z51 TRACK PREPARATION

DUAL CLUTCH TRANSMISSION FLUID

Transmission fluid and external filter should be changed after every 24 hours of track usage. If prompted by the transmission fluid life monitor that remaining fluid life is low, the fluid and filter should be changed as soon as possible.

Add an additional 2 qt (2 L) of DCT transmission fluid prior to track usage. It is not required to remove the additional 2 qt (2 L) of DCT fluid.

Any transmission level set or change should be performed at your dealer. The transmission fluid used in the dual clutch transmission is a specific transmission fluid. Use of unapproved fluid may cause damage to the transmission. See your dealer for the proper transmission fluid.

5. DRIVER MODE AND PTM SETTINGS (if equipped)

DRIVER MODE SELECTOR

Track mode should be selected for track use or competitive driving. The outer ring of the Driver Mode Selector is located on the console under the wrist pad. It rotates to change the modes, which display in the instrument cluster. You can also set desired track settings for the steering wheel-mounted Z-mode button.

COMPETITIVE DRIVING MODE

Competitive Driving mode allows full engine power, while StabiliTrak/ESC helps maintain directional control of the vehicle by selective brake application. In this mode, the TCS is off and Launch Control is available.

Adjust your driving style to account for the available engine power. In order to select this optional handling mode, the vehicle mode must be set to Sport or Track. If equipped with Performance Traction Management (PTM), then Competitive Driving mode is only available in Sport. Then, quickly press the traction control button on the center console two times. ESC COMPETITIVE MODE displays in the Driver Information Center (DIC).

PERFORMANCE TRACTION MANAGEMENT

Corvette models that are equipped with Z51 Performance Package and Magnetic Selective Ride Control™ incorporate Performance Traction Management (PTM), which integrates the Traction Control, StabiliTrak® and Selective Ride Control systems to provide consistent performance when cornering in track situations.



2021 CORVETTE Z51 TRACK PREPARATION

TO UTILIZE PTM

- / The vehicle must be in Track mode.
- / Quickly press the TCS/StabiliTrak button on the center console two times.
- / To select a mode, turn the Selective Ride Control/Performance Traction Management MODE SELECT knob.
- / PTM contains five modes. Mode 5 is Race with Active Handling off. It is for use by experienced drivers who are familiar with the track, requires the most driving skill and should be used in dry conditions only. StabiliTrak is off and engine power is available for maximum cornering speed.

Note: For full details and information, see the vehicle Owner's Manual.

AFTER THE TRACK

After driving your Stingray with Z51 Performance Package on the track, it is important to return the vehicle back to the original factory settings with the proper fluids before normal street driving.

STEP 1	STEP 2	STEP 3	STEP 4	STEP 5	STEP 6
Return the tire pressure settings to factory (see the Tire and Loading Information label located below the door latch with the door open).	Return the wheel alignment settings to factory.	Replace oil (use only engine oil licensed to the dexos1™ specification of the proper SAE-viscosity grade).	Replace brake fluid (DOT-4 Hydraulic Brake Fluid). Note: Remove the track only rear lower control arm brake duct.	Rotate the Driver Mode Selector out of Track mode.	Return to production trim height.

Note: For full details and information, see the vehicle Owner's Manual.

WARNING: Prior to each track event and again before returning to public roads, tighten the wheel nuts with a torque wrench to the proper torque specification. Wheel nuts that are improperly or incorrectly tightened can cause the wheels to become loose or come off, resulting in a crash. See Capacities and Specifications in the vehicle Owner's Manual for wheel nut torque specifications.

For full details and information, see the vehicle Owner's Manual.

Certain restrictions, precautions and safety procedures apply to your vehicle. Please read your Owner's Manual for complete instructions. All information contained in this guide is based on the latest information available at the time of printing and is subject to change without notice. Copyright 2020 General Motors. All rights reserved.